

# INSTRUCTIONS FOR USE

## 270-F Series Gear Type Tube Bender

For bending soft and hard copper, aluminum, brass, steel and other tubing and pipe of bending temper

### For 3/8" to 1-1/8" O.D. tubing.

For all bending work. Spur-gear type with 10-to-1 ratio for easy bending of tempered tubing. Floating shoe aligns tube perfectly on calibrated forming

wheel. Pull-pin on wheel speeds repositioning for bends over 90°. Portable. Can be hand held, clamped in vise or bolted to bench. Adapts to pipe vise with handle 271-F.



**1** FOR MAKING RIGHT HAND BENDS, hold tube across shoe face.



**2** Attach forming wheel with hook point facing down and chained center pin inserted in left hole. Bender body handle will be closest to you and shoe, farthest away. Drop hook in place over tubing.



**3** Turn handle clockwise until desired degree of bend is obtained. Handle may be extended to full width to give maximum leverage. To remove bent tubing pull out center pin, thus releasing forming wheel and tubing.

### BENDING RADII

Part No.	O.D. of Tube	Nominal Tube Size	Bending Radius to Center of Tube	Minimum Return or Coil Bend from Center to Center of Tubing
270-F-06	3/8"	1/4"	1-3/4"	4-1/2"
270-F-08	1/2"	3/8"	2-1/2"	6"
270-F-10	5/8"	1/2"	3"	7-1/2"
270-F-12	3/4"	5/8"	4"	9-1/2"
270-F-14	7/8"	3/4"	4"	9-1/2"
270-F-16	1"	7/8"	4"	9-1/2"
270-F-18	1-1/8"	1"	4"	9-1/2"

FOR MAKING LEFT HAND BENDS, turn forming wheel over with hook point face up and hold in place with center pin in right hole. Bender body handle will be closest to you and shoe, farthest away. Turn handle counter-clockwise.

**⚠WARNING - Always wear approved eye protection.**

**IMPORTANT:** Lubricate pinion, center pin and inner surface of shoe with oil or grease. This is especially important for hard-to-bend tubing as it will make bending easier.

# GUIDE FOR MAKING DIMENSIONAL BENDS WITH IMPERIAL UNIVERSAL GEAR-TYPE TUBE BENDERS

TO OBTAIN "X" DIMENSION, TUBE SHOULD BE PLACED IN BENDER AS ILLUSTRATED IN FIGURES 1 AND 2

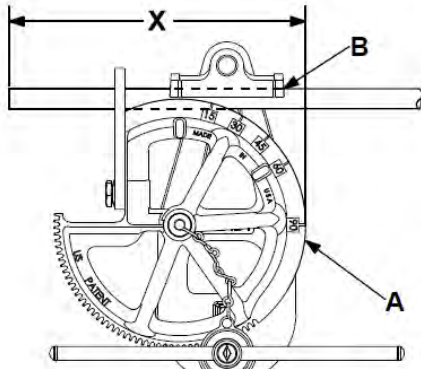
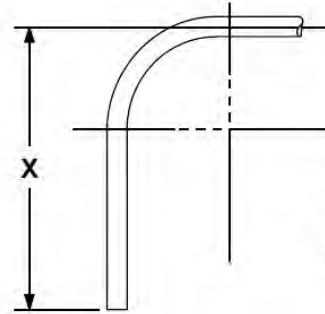

FIG. 1



A - MANDREL  
B - SHOE

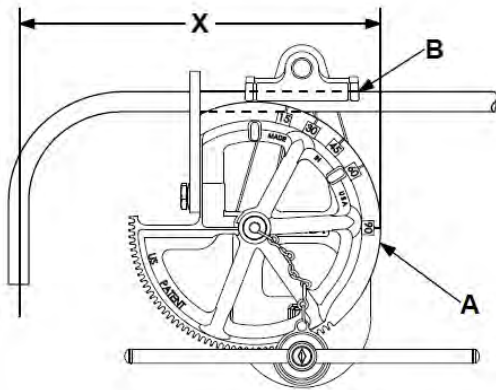

FIG. 2

